



## SHADE SAIL ANCHOR INSTALLATION GUIDE

### General Installation

1. Remove roofing tiles or lift roof sheets to achieve an opening to fit the Roof Extenda Shade Sail Anchor.
2. Bolt the section with the steel rod & the backing plate to the selected rafter using 2 x M12 hex bolts. Secure both brackets to the top plate with 2-M10 coach screws through to each bracket.
3. Replace the roof tiles or roof sheet, cutting a hole to allow the loop to penetrate the roof.



### Care Instructions

Roof Extenda recommends painting mild steel brackets before installation. The anchor to be cleaned and inspected yearly and re-coated if required.

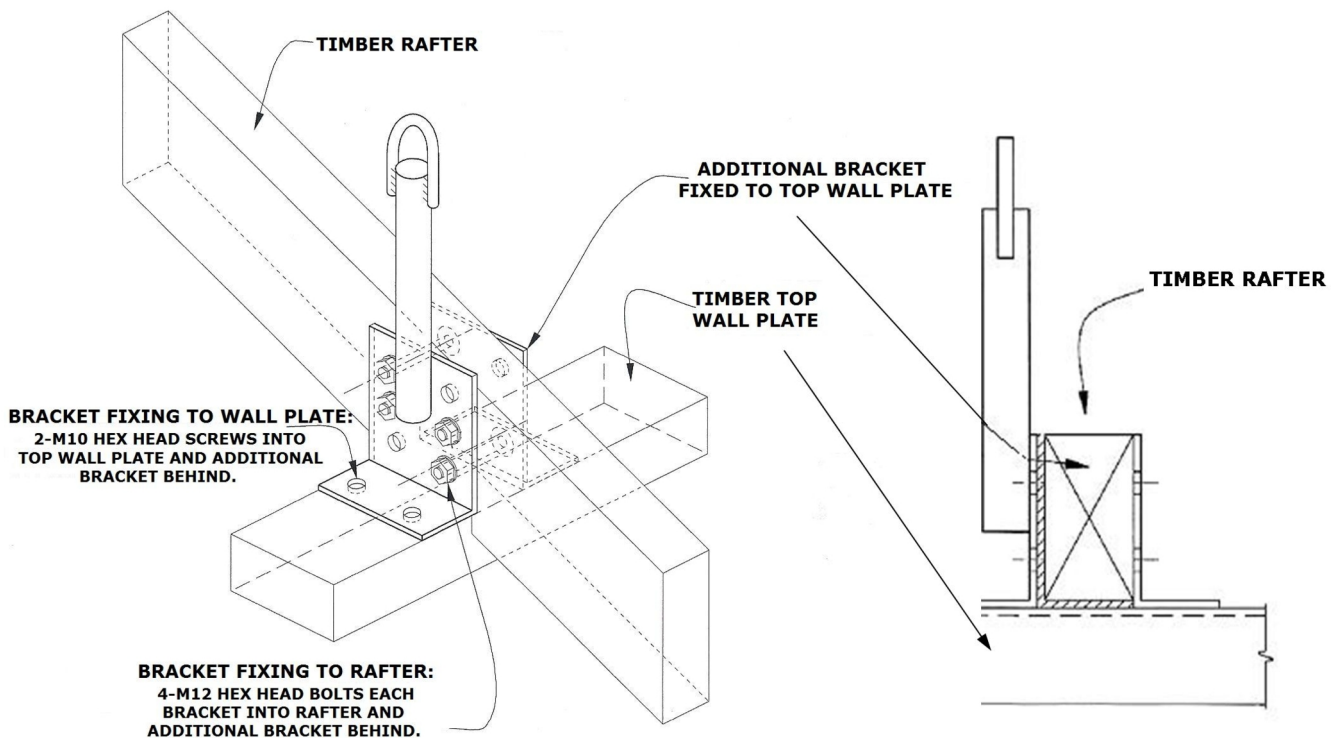

### Note

Local Council or Shire approval may be required prior to construction. Roof Extenda accepts no responsibility for the type of construction undertaken. The Shade Sail Anchor has been strength tested. When bolted in the top holes, the Anchor can deform at 2.3kN of force. When bolted in the middle holes, the Anchor can deform at 1.3kN of force. We advise you carefully evaluate the shade sail size, location, wind category & installation design before purchasing.

## FlashRite Weather Seal

If using a FlashRite weather seal it is fitted to the top bracket.

- 1 Cut cone to exact corresponding pipe diameter. We recommend a sharp pair of scissors to cut our pipe flashing for the correct pipe size. Ensure there are no accidental nicks in the polymer, as this will continue to split/tear over time.

**Tip:** Ensure the blades are sharp with no contamination e.g. glue or any accumulated dirt.

- 2 Lubricate the top bracket with water prior to attaching the weather seal.
- 3 Attach the weather seal to the top bracket then wind the top bracket down to the desired height and lock the hex nut tightly.
- 4 Form the weather seal to the profile of the roof and mark out the position of the weather seal.
- 5 Slide the weather seal up the bracket to apply neutral cure sealant inside the area marked, press the weather seal into position and finish with a bead of sealant to the edges of the weather seal to complete the fitting.
- 6 Realign weather seal onto roof and fix with Class 3 or Class 4 hex head self-drilling screws minimum of 16mm long with a rubber washer.

### If Retro-Fitting a Weather Seal:

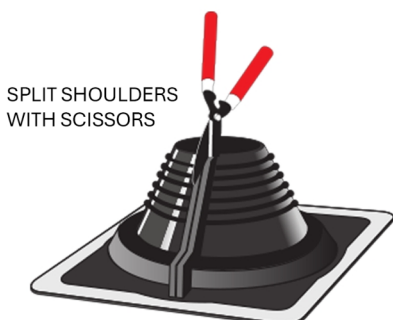

CRIMP FLASHING SHOULDERS WITH RETROFIT CLIPS. FACE JOINT DOWNSTREAM.

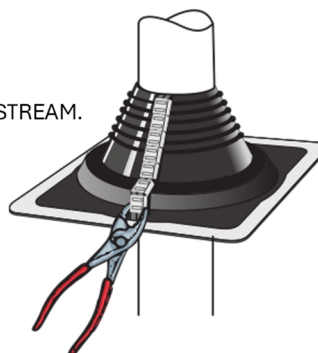

CUT CONE TO EXACT CORRESPONDING BRACKET PIPE DIAMETER

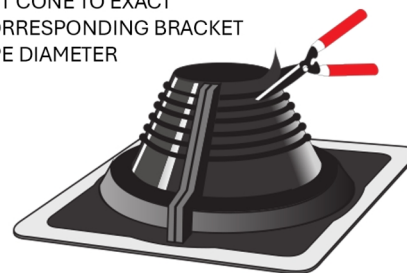

WHEN SLIDING FLASHING DOWN TOP BRACKET PIPE WITH WATER

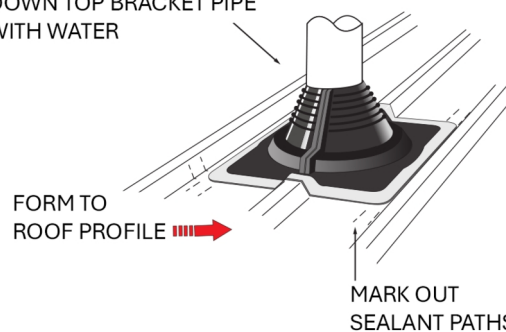

LIFT FLASHING UP TOP BRACKET PIPE

APPLY SEALANT ON MARKED PATH

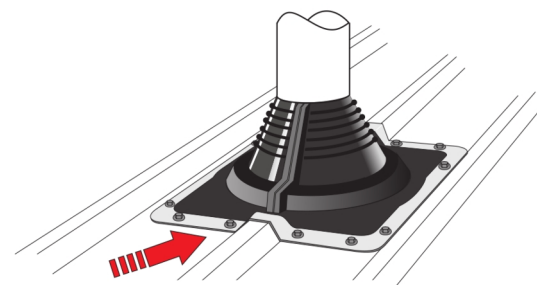
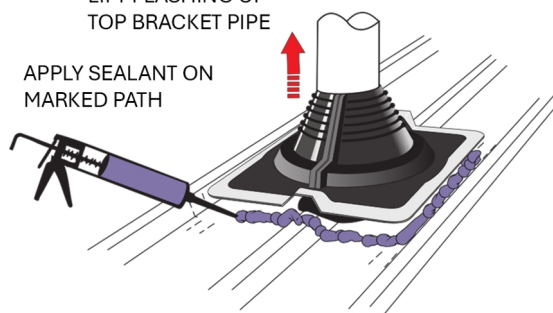

## Flexatile

- 1** Ensure tiles are cleaned before installing the Flexatile flashing to ensure the butyl adhesive strips can have maximum effect when bonded to the tiles.
- 2** Cut the rubber cone at least 15mm smaller than the top bracket pipe's outside diameter with a sharp pair of scissors. Ensure there are no accidental nicks in the polymer, as this will continue to split/tear over time.  
  
*Tip: Ensure the blades are sharp with no contamination e.g. glue or any accumulated dirt.*
- 3** Remove the middle lining from the underside of the flexatile.
- 4** Lubricate the top bracket with water and slide the flashing down the bracket.
- 5** Form an anti-capillary fold at top of base sheet.
- 6** Remove the protective backing from the underside of the flashing, that is covering the butyl adhesive strips.

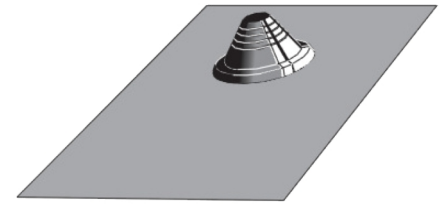

BASE SHEET CHOICE  
a) ACRYFLASH  
b) ALUMINIUM  
c) RE-INFORCED POLYMER

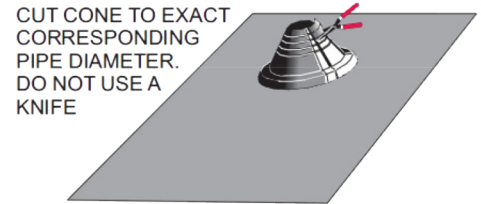

CUT CONE TO EXACT CORRESPONDING PIPE DIAMETER. DO NOT USE A KNIFE

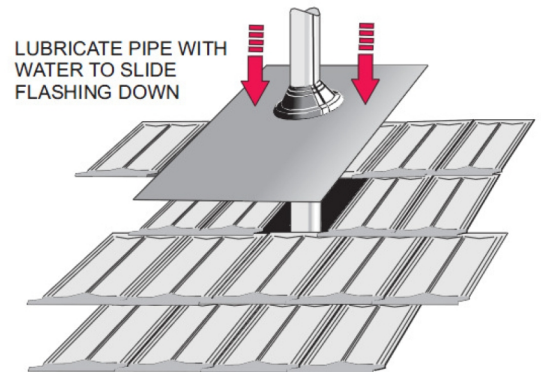

LUBRICATE PIPE WITH WATER TO SLIDE FLASHING DOWN

- 7** Hand form the base all around the tile and apply pressure to the butyl adhesive side strip.

FORM AN ANTI-CAPILLARY FOLD AT THE TOP OF THE BASE SHEET

ENSURE ANTI CAPILLARY FOLD IS NOT DEFORMED AT TOP

DOUBLE SIDED FOAM TAPE IS AVAILABLE FOR BOTH SIDES

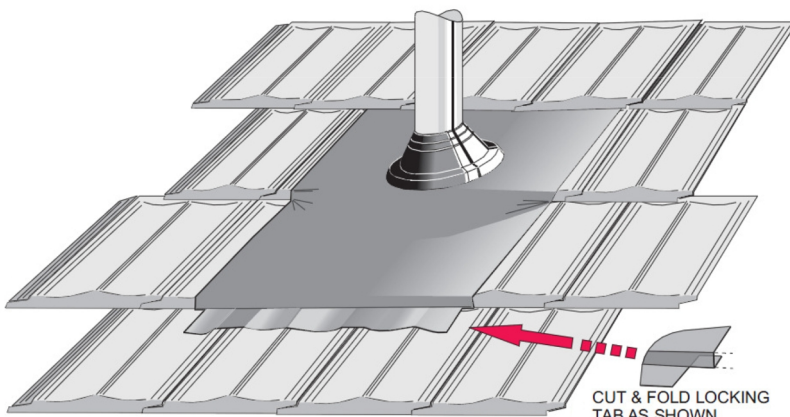
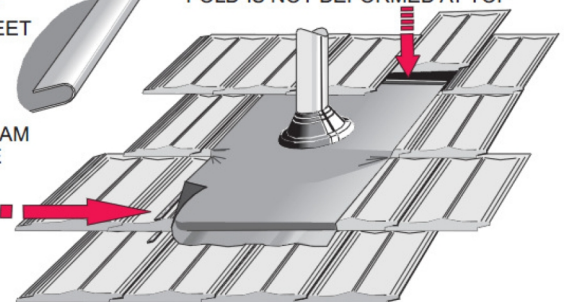

CUT & FOLD LOCKING TAB AS SHOWN